

A Dynamical Control in Multilevel Converter Using an Adaptive Learning Algorithm

¹Mohan S. Selokar

² Manoj Sankhe

Research Scholar, MPSTME Mumbai

Professor and Head EXTC Dept., MPSTME Mumbai

Article Info

Volume 83

Page Number: 62 - 71

Publication Issue:

September/October 2020

ABSTRACT

There is a wide use of multilevel converters as they can be used with high power and high voltage applications. A multilevel converter consists of large number of voltage levels in load voltage and load current. A multilevel converter has number of various advantages like good quality of output voltage waveform, smaller values of inductor and capacitor in passive filters. The output consists of less harmonics. Reduction in total harmonic distortion can be obtained with the help of multilevel converter. Using learning algorithm like neural network, output voltage is controlled. Error in the reference voltage and output voltage is reduced. Neural network replaces the PI controller completely. A reduction in THD in output voltage and output current can be obtained by neural network by large margin as compared to PI controller. This increases the wide application of AC motor as load as it reduces torque pulsation and RF/EMI effect. It increases the efficiency by reducing power losses.

Keywords: Multilevel inverter; Cascaded H-Bridge multilevel inverter; Total Harmonic Dist

Article History

Article Received: 4 June 2020

Revised: 18 July 2020

Accepted: 20 August 2020

Publication: 15 September 2020

ortion; Sinusoidal pulse width modulation;

1. INTRODUCTION

The use of high power is increased very widely in industrial applications. Now days there is requirement of quality power[1]. A multilevel converter is consists of several levels of dc voltage as inputs and produces a required voltages. This technology of multilevel converter is growing at rapid rate. Multilevel converter is very widely used with non-conventional energy sources like wind, solar. PV cells are widely used as input sources to the multilevel converter.

The output of multilevel converter consists of different steps of smaller voltage. It has lower switching losses. The output consists of lower harmonic components. It can generate high power as required by application. It generates high power quality [4]. Multilevel inverters can be used with high frequency and low frequency PWM. But high frequency PWM shows high frequency switching losses and lower efficiency and low frequency PWM results in low losses and higher efficiency [5].

The use of multilevel converter is highly associated with windmills. It is widely used in pumps, conveyor, grid and HVDC. These are the following various topologies suggested for multilevel inverters like cascaded multi cell with different dc batteries, diode clamped and capacitor clamped[6]. These various mechanisms suggests the way of generation of output voltage and current [7]. Cascaded H- bridge consists of different power converter units connected in series. With this type of

PI Controller; Neural Network.

connection voltage level and power level can be scaled easily. Diode- clamped inverter uses a group of series capacitors [8]. Flying capacitor uses capacitors in floating conditions to clamp the voltage levels, instead of series connected capacitors [9]. Cascaded H-bridge inverters neither use flying capacitors nor clamping diodes but isolation transformers to provide the isolation among different input voltagesources.

There are various modulation methods and control mechanisms used for the control purpose in multilevel converter. For example pulsewidth modulation of sinusoidal type (SPWM), selective harmonic elimination using PWM (SHE-PWM), space vector modulation (SVM), and others[10], [11]. Each unit power converter requires different switching angle. To generate switching angle, sinusoidal pulse width modulation is used with high carrier frequency. Average output voltage should remain unaffected. Various advantages like low quantity ripples in input current, lower values of filter capacitor and filter inductor, decrease in output voltage THD and a large gain in desired boost factor are offered by multilevel converter [12]. Also, many multilevel converters are focused on applications such as medium and low voltage motor drives in industrial application [13], interface in which renewable energy is the requirement of various systems [14], transmission systems in

which flexible AC is used (FACTS) and traction drive systems [15], [16]. Improvement in the good power quality in the distribution network, shunt Active Filters used for voltage using PI, PID and Fuzzy Logic Controller (FLC) for power line conditioners (PLC) have been suggested [17]. Desired value of output voltage level to provide the power for a variation in loads with a minimum THD, a deadbeat-based proportional-integral (PI) controller with battery cell as the main energy source for a stand-alone single-phase inverter with voltage source has been suggested [18].

A special single phase nine-level inverter chooses configuration with full bridge by using compatible sinusoidal modulation method as in the case of power circuits. The output voltage is increased from zero to four times V_{dc} in steps of V_{dc} and again decreased from four times V_{dc} to zero. In negative half cycle output varies from zero to four times $-V_{dc}$ and again to zero in steps of V_{dc} . By using appropriate frequency for carrier and relations for switching the contents of the harmonic in output voltage are recalculated. Therefore, significant reduction in harmonics is obtained to a great extent.

This paper explains and demonstrated a nine level inverter in which output voltage can be obtained in nine levels. The harmonic content can be decreased if the number of output levels in the output voltage which results in the reduction of THD. New switching strategies is

suggested by designing alternative circuit topological structures and by proposing suitable control method in order to reduce THD. In view of the inherent merits,

Cascaded H-bridge inverter and SPWM control strategy are used in this work. We use cascaded H-bridge inverter topology in which four reference signals are used to obtain PWM signals for the power electronic devices (switches).

A neural network is used to control the harmonic content present in load voltage and load current. Neural network is trained using data sets obtained with the use of P-I controller. Voltage controlled feedback is used in this scheme. The application of neural networks is recently growing in the power electronics and drive areas. In inverters voltage control is used in ac drives application. In this paper harmonic elimination in PWM inverter is suggested. The switching angles to generate the output voltage is used. These angles are used in PWM to generate the pulses.

After the introduction in section 1, Section 2 explains cascaded H-bridge multilevel inverter topology. The two sections 3 and 4 show the simulation results that ensure the correct functioning of the inverter with the neural network. Conclusion of the work done so far and final remarks are made in Section 5.

2. CASCADED H-BRIDGE NINE LEVEL INVERTER

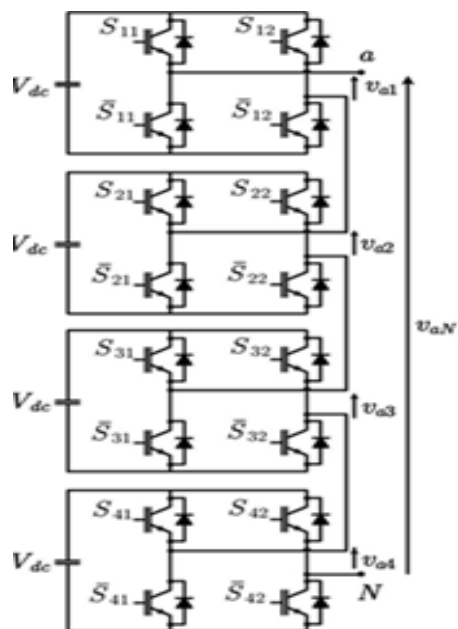

Figure 1: connection schematic of a single phase cascaded H- bridge Nine level Inverter

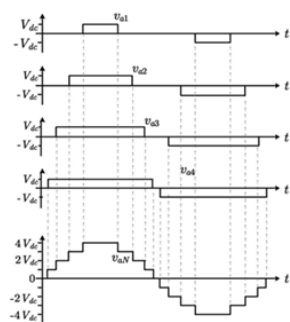

Figure 2: load voltage waveform of a cascaded nine level Inverter

Fig. 1 and 2 show the Schematic diagram and voltage waveform across the load of single-phase cascaded h-bridge

nine level inverter. A single phase nine level inverter is constructed in which there is a requirement of four identical converter units. Four converter units are connected in series. Each power converter unit is applied with dc voltage source of same magnitude. During the positive half cycle of output voltage two switches namely (S_{11}, \bar{S}_{12}) goes into on state and two switches namely (S_{12}, \bar{S}_{11}) goes into the off-state. Similarly, during the negative half cycle of output voltage switches (S_{11}, \bar{S}_{12}) remains in the off-state, and switches (S_{12}, \bar{S}_{11}) goes into the on-state and vice versa. The output of multilevel converter consists of nine voltage level starting from zero to four times v_{dc} and from zero to negative four times of v_{dc} again back to zero. Cascaded H-bridge inverter which is a series of single unit of power converter connected to another. Each unit of power converter is responsible to generate one level in positive side and one level in negative side of output voltage.

The number of levels present in output voltage is the sum of levels in positive side, negative side and zero level. The number of level be denoted by m and let n be the number of power converter units in a particular multilevel inverter, then number of levels in output voltage are given by,

$$m=2n+1 \quad (1)$$

3. GENERATION OF PULSES USING NEURAL NETWORK

PI controller can be used above has limitations. The output of PI controller is continuous. Therefore for small change in the load can not minimize the error signal. We propose the technique based on learning algorithm. Output voltage control for wide range of output voltage range is to be achieved. For the change in load values constant output voltage is to be maintained. Therefore the various data values for input and output of PI controller are collected in .mat file to train the neural network. The neural network mimics the human brain. Input output combinations can be used with very small interval. The output of ANN block is applied to PWM generator to generate pulses to trigger MOSFETs.

The neural network can be used as robust controller. Constant output voltage is the requirement of loads specially for AC motors. The ANN used here is proved to be a good replacement of PI controller. The ANN used has two hidden layer, one input layer and one output layer. Each hidden layer consists of ten neurons and both input and output layers consist of five neurons.

ANN output determines the switching angles of the nine level CHB inverter. A NARX (Nonlinear Autoregressive with external Input) model is used for ANN. There are NAR(nonlinear Autoregressive) and Nonlinear Input-output models are also available. In NARX model feedback is used with external input. As feedback is used in NARX model error is minimized to low value. A neural network is trained by a data samples collected with the use of PI

controller. The Modulation index used here is 0.8. In ANN dynamic time series model is employed. The values of gain used for PI controller has 0.1 as proportional gain and 0.01 as integral gain. The total data samples used are 29981. Data samples and error histogram obtained are shown in fig. 5 and Fig. 6 respectively. From the error histogram it is shown that error lies in the acceptable limits. The tested data gives the output very close the calculated data. The simulation is done with Matlab Simulink. The parameters for the Matlab simulation used are shown in Table 1. The LC filter is used for filtering before the application of voltage to the load. The neural network output is fed to the PWM generator as modulating signal. Very high frequency is used to generate the gating pulses. The very high frequency gating pulses are generated to minimize amplitude of nearby odd order harmonics. Using FFT analysis it shown very clearly that THD content in output voltage and current is minimized.

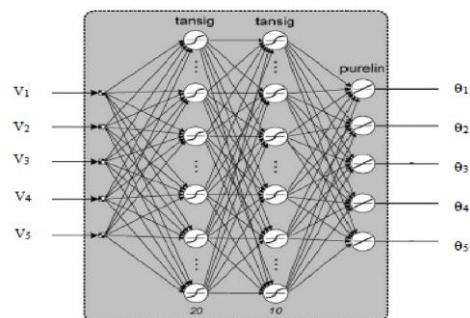

Figure 3: Neural Network structure

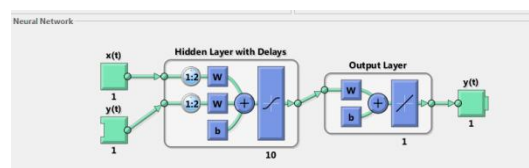
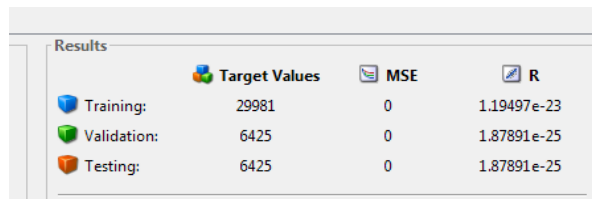

Table 1: Simulation parameters

Parameters	Values
Levels in load voltage waveform	4
Power Electronic Switches (Mosfets)	16
Potential of DC source used for single H-bridge unit	50 V
Fundamental frequency	50Hz
Switching Frequency	1350 Hz
Load resistor	100 Ohm
Load inductor	40mH
Filter inductor	40mH
Filter capacitor	50 microfarad

Figure 4: Neural Network structure used



	Target Values	MSE	R
Training:	29981	0	1.19497e-23
Validation:	6425	0	1.87891e-25
Testing:	6425	0	1.87891e-25

Figure 5: Data samples

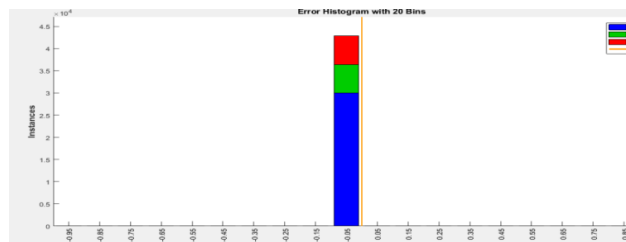

Figure 6: Error Histogram
NARX model is used for neural network.

4. SIMULATION RESULTS

MatlabSimulink is powerful tool to simulate the circuit. Mosfets are used with

snubber circuits are used, The on state voltage drop here is very less by selecting very less value on state resistance. PWM generator block is selected with internal generation of carrier signal with very high value of carrier frequency in the order of 27*50 Hz. The reference signal has the frequency of 50 Hz and peak amplitude of 200V. The 50 V dc input voltage is used for each converter.

The performance of the ANN based cascaded H-bridge nine level inverter with isolated dc sources is determined through MATLAB/ SIMULINK software. The elements and the parameters considered for simulation are presented in table 1. The simulation without ANN and with ANN is carried out for comparison.

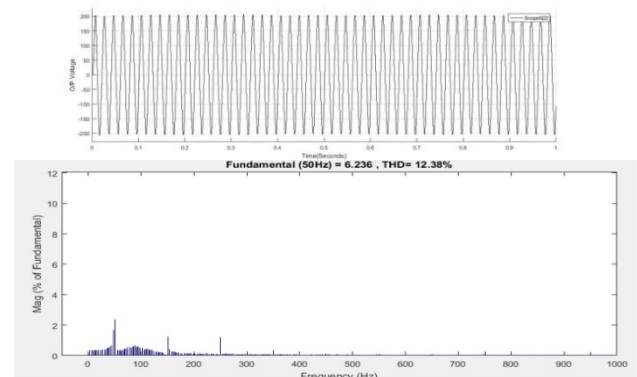

Figure 7: Voltage waveform and FFT Analysis for Output Voltage Waveform (PI controller)

The main power circuit consists of four H-bridges. The dc voltage used for each cascaded H-bridge module is 50 V and the nine level stepped output voltage is achieved. The total harmonic distortion present in output voltage is reduced by

great extent. The calculation of THD is calculated using FFT analysis.

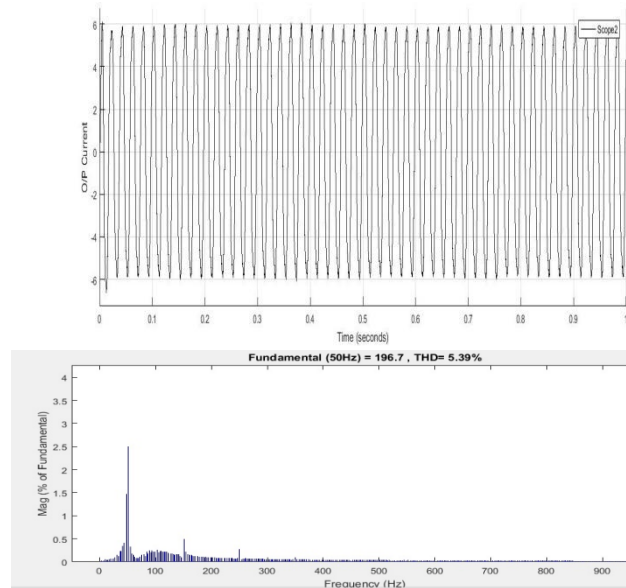

Figure 8: Current waveform and FFT Analysis for Output Current Waveform (PI Controller)

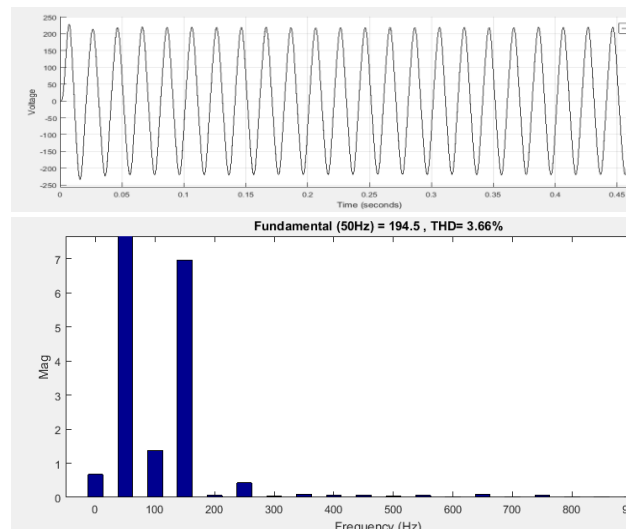

Figure 9: Voltage waveform and FFT analysis ANN based Multilevel converter

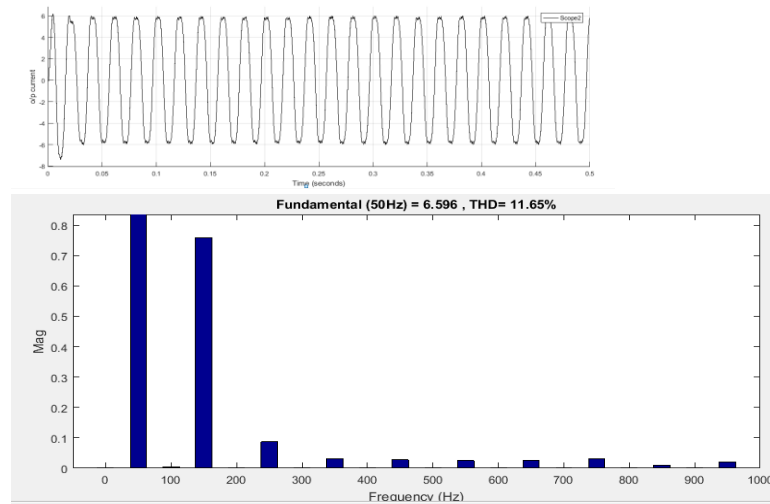

Figure 10: Current waveform and FFT analysis ANN based Multilevel converter
PWM block has the facility to determine the modulation index which is the ratio of peak of modulating signal to peak of the carrier signal. With this block, amplitude frequency and phase delay is adjusted. The shape of the output voltage waveform is decided by selecting the parameters of the PWM block. Ripples are reduced and efficiency of the DC to AC conversion is increased. In Multilevel converter it is possible to deliver very high voltage and good quality of power with less harmonics with the help of Neural Network. The resistive-inductive loads are connected across the cascaded H-bridge nine level inverter. Output voltage remains constant to the reference value. The total harmonic distortion is 5.39%. The total harmonic distortion in current waveform is 12.23% with the PI controller whereas with the help of ANN. The THD content in voltage and current waveform is reduced to 11.65% and 3.66% respectively.

Table 2: Comparison of various techniques

Sr. No.	Implemented Techniques	THD in o/p current	THD in o/p Voltage
1	Voltage feedback PWM	12.38%	5.39 %
2	Voltage feedback PWM using ANN	11.65%	3.66%

5. CONCLUSION

The implementation of PI control strategies for single phase cascaded h-bridge nine level inverter have been carried out using Matlab Simulink. The data obtained with PI controller is used to train the ANN. ANN used proved to be more advantageous than PI controller. With the result it is proved that the THD in output voltage and current is less as compared with the use of PI controller. The ANN controller can be used with the load like AC motor in which high efficiency and less value of THD is required for high performance of AC motor.

6. REFERENCES

1. J. Rodriguez, J. S. Lai and F. Z. Peng, "Multilevel inverters: Survey of topologies, controls, and applications," *IEEE Trans. Ind. Elect.*, vol.49, no.4, pp. 724-738, Aug.2002.
2. Beser, E.; Camur, S.; Arifoglu, B.; Beser, E.K., "De-sign and application of a novel structure and topology for multilevel inverter," in *Proc. IEEE SPEEDAM*, Tenerife, Spain, 2008, pp. 969 –974.
3. R.H. Baker, "High-Voltage Converter Circuit," U.S. Patent Number 4,203,151, May1980.
4. S. Mekhilef and M. N. Abdul Kadir "Voltage control of three-stage hybrid multilevel inverter using vector transformation" *IEEE Trans. Power Electron.*, vol.25, no.10, pp 2599-2606, Oct.2010.
5. L.M. Tolbert, F. Z. Peng, T. G. Habetler, "Multilevel PWM Methods at Low Modulation Indices," *IEEE Trans. Power Electron.*, vol. 15, no. 4, pp. 719-725, July2000.
6. M. N. A. Kadir S. Mekhilef, and H. W. Ping "Voltage vector control of a hybrid three-stage eighteen- level inverter by vector decomposition" *IET Trans. Power Electron.*, vol.3, no. 4, pp.601- 611, 2010.
7. E.Babaei, M.T.Haque, and S.H.Hosseini, "A novel structure for multilevel converters," *Proc. ICEMS, 2005*, vol. 2, pp.1278–1283.
8. A.Nabae, I. Takahashi, and H. Akagi, "A new neutral-point clamped PWM inverter," *IEEE Trans. Ind. Applicat.*, vol. IA-17, no. 5, pp. 518– 523, Sep./Oct 1981.
9. T. A. Meynard and H. Foch, "Multilevel conversion: High voltage choppers and voltage-source

- inverters,” in *Proc. IEEEPESC, Toledo, Spain* 1992, pp. 397–403.
10. S. Mekhilef and M. N. Abdul Kadir “Novel vector control method for three-stage hybrid cascaded multilevel inverter” *IEEE Trans. Ind. Elect.*, vol. 58, no. 4, pp. 1339-1449, May 2010.
 11. S. Mekhilef, A. M. Omar and N. A. Rahim, “Modeling of three-phase uniform symmetrical sampling digital PWM for power converter” *IEEE Trans. Ind. Electron.*, vol. 54, no. 1, pp. 427-432, Feb. 2007.
 12. Carlos Roncero-Clemente, Oleksandr Husev, V. Miñambres-Marcos, Enrique Romero-Cadaval, Serhii Stepenko, Dmitri Vinnikov, “Tracking of MPP for three-level neutral-point-clamped qZ-source off-grid inverter in solar applications”. *Informacije MIDEM. Journal of Microelectronics, Electronics Components and Materials. ISSN 0352-9045*, Vol. 43, No. 4, 2013, pp. 212-221. Dec. 2013.
 13. M. F. Aiello, P. W. Hammond, and M. Rastogi, “Modular Multilevel Adjustable Supply with Parallel Connected Active Inputs,” U.S. Patent 6301 130, Oct. 2001.
 14. L. M. Tolbert, F. Z. Peng, “Multilevel converters as a utility interface for renewable energy systems,” in *Proc. IEEE Power Eng. Soc. Summer Meeting 2000*, vol. 2, pp. 1271-1274.
 15. L. M. Tolbert, F. Z. Peng, T. G. Habetler, “Multilevel Inverters for Electric Vehicle Applications,” IEEE Workshop on Power Electronics in Transportation, Dearborn, Michigan, 1998, pp. 1424-1431.
 16. M.N. Abdul Kadir S. Mekhilef and H. W. Ping, “Dual vector control strategy for a three – stage hybrid cascaded multilevel inverter,” *Journal of power Electronic*, vol. 10, no. 2, pp. 155-164, 2010.
 17. P. Karuppanan and Kamalakantamahapatra, “PI, PID and Fuzzy logic controlled cascaded voltage source inverter based active filter for phone line conditioners”, *Wseas transactions on power systems*, vol. 6, no. 4, pp 100-109, Oct 2011.
 18. Towleong Tiang and Dahamen Ishak, “Modelling and simulation of dead beat based PI controller in a single phase H-bridge inverter for standalone applications”, *Turkish journal of electrical engineering and computer sciences*, 22, pp 43- 56, 2014.

Authors



Mohan S. Selokar: Mohan S. Selokar obtained B.E. (Electronics) from Dr. BAMU Aurangabad. He obtained post graduate degree of M.E. from university of Mumbai. He has teaching experience of 23 years. He has published various research papers in international conferences. He is a life member of the Indian Society of Technical education (ISTE). His current research interests include power electronics and controls.



Manoj Sankhe: Dr. Manoj S. Sankhe has received B.E in electronics Engineering from Pune University in 1996, M.E. in Digital Electronics from Amravati University in 2002, and Ph.D degree in Electronics engineering from NMIMS in 2014. He has more than 23 years of experience in teaching & 1.5 years of experience in industry. He is currently working as the Professor & Head of Department of Electronics & Telecommunications and I/C Head of Electrical Engineering Department at Mukesh Patel School of Technology Management and Engineering, SVKM'S NMIMS University, Mumbai. He is a life member of the Indian Society of Technical education (ISTE). His current research interests include power electronics and drives, Biomedical Electronics, Optical communication Networks and Electronics Circuit Design. He has published 25 papers in National / International Conferences and Journals, one book chapter and one patent to his credit.

He has been awarded the "Best Concept Note" under the theme Technology Innovations in Diagnostic / Prognostic, Health Tech Innovations – 2015 Conference,

organised by Society Applied Microwave Electronics Engineering & Research (SAMEER), IIT Bombay under the aegis of Department of Electronics and Information Technology, Government of India in technical collaboration with National Health Systems Resource Center (NHSRC) & Indian Council of Medical Research (ICMR).

He has been awarded the "Best Faculty" award from the auspicious hands of Dr. Sekar Basu, Director BARC and Dr. Rajan Saxena, Vice Chancellor, NMIMS, in SVKM'S NMIMS, Mukesh Patel School of Technology Management and Engineering, Convocation, 8th August 2015 for the academic year 2014-2015.