

# Automatic Overtaking System for Avoiding Accident

Pranali S. Dange<sup>1</sup>, Bhakti R. Bansod<sup>2</sup>, Rajnandinee L. Badage<sup>3</sup>, Prof. Aniket Katade<sup>4</sup>

<sup>1</sup>Computer Engineering Department, VIIT, Pune, India

<sup>1</sup>pranali.dange01@gmail.com, <sup>2</sup>bansodbhakti33@gmail.com, <sup>3</sup>nandineebadage@gmail.com,

<sup>4</sup>aniket.katade@gmail.com

## Article Info

Volume 82

Page Number: 13348 - 13352

Publication Issue:

January-February 2020

## Article History

Article Received: 18 May 2019

Revised: 14 July 2019

Accepted: 22 December 2019

Publication: 24 February 2020

## Abstract

Transportation has become one of the significant parts of our lives. Over time, the technology of our vehicles has changed dramatically. Today large numbers of cars run continuously. Nowadays, the number of accidents is increasing day by day due to the negligence of the driver.

We have found that the existing system for Accident Avoidance includes controlling only the speed of a vehicle and applying brakes. But, our policy will not just help to overtake the cars automatically without any manual efforts but also will help to identify whether the driver is a drunkard or not? Hence, by using the principle of Fuzzy Logic, the sensors or the probes present on the vehicle will be used to collect and calculate the distance between the neighbouring obstacles or vehicle and itself. When this distance reduces, the sensors that are present on the car will sense them, and the overtaking mechanism will take place. Implementing this system will surely reduce the number of road accidents.

**Keywords;** Vehicle, Obstacle, Overtake, Sensors

## I. INTRODUCTION

According to the survey of the Ministry of Road Transport and Highways, The number of road accidents per lakh population has been increasing since the 1970s. Around 84% of road accidents has risen from the year 1980 to 1990. Drivers are responsible for 78% of crashes. 3% of crashes are due to the negligence of people on the road. Mostly maximum number of accidents are caused because of the Driver's fault. Some causes of accidents are speed, hit and run cases or drink and drive cases. About 7.1% of accidents are caused due to the failure of cyclists or pedestrians. 2.3% of accidents are caused due to the defect in a motor vehicle. 1.7% of accidents are caused due to weather conditions.

Road accidents are a significant public health problem stated by the World Health Organization as crashes kill more than 1.25 million people and injure about 50 million people a year, with 90% of such casualties occurring in developing countries. Every four minutes there is one death in India due to a road

accident. One of the leading cause of road accident is drunken driving. [4]

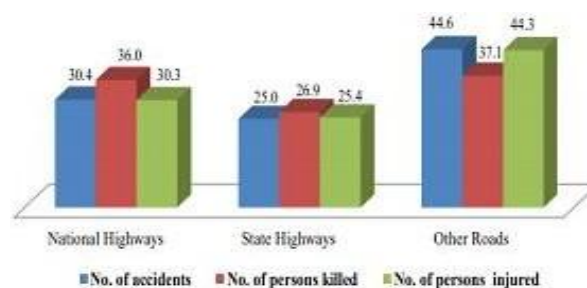

**Fig. 1. Causes of Road Accidents in the year 2017**

The primary purpose of proposing this technology is to avoid the accidents that are always taking place from day-to-day. According to the survey, it is found that the current technology suggests only applying brakes and stopping for the obstacle to pass away or manually overtaking that obstacle. Also, the restraints of the vehicle will be used when it will reach very close to the barrier.

Therefore we proposed this system not just to apply brakes when an obstacle is detected but also pass the

vehicle or any obstacle by overtaking it as well as check whether the driver has consumed alcohol or not? Because of this system, the speed will not exceed and will be in control, which will avoid the accident, and the driver will be safe. This system will have a very significant impact on the society of people as using this system the number of accidents will get reduced. In this system, the combination of automatic overtaking and alcohol detection will give more and more benefits for the people using it and getting avoided from accidents.

## II. LITERATURE SURVEY

We did some surveys to find out whether such devices are already present, which may avoid accidents, and we have found that the existing technology only makes the vehicles slow down and apply brakes. When the car detects any obstacle in its range, the car will automatically apply its brakes. This technology is already implemented by Volvo, which is called as PAT – Pedestrian Avoidance Technology.



**Fig. 2. The PAT system in a Volvo car detecting obstacles in each direction in front of it**

The existing system used by Volvo, as shown in the figure, sends the IR beams in each direction in front of it and detects obstacles. When an obstacle is found, it merely beeps and applies brakes and stops just before colliding with the barrier. This can somewhat be a little risky to stop right before it hits the obstacle.[2]

We had referred "Automatic Overtaking for Accident Avoidance and Automatic Windscreen Wiper" paper. The Authors of this paper are MsShweta B. Bansude, MsAnuja M. Bhosale. They

had developed a system that applies brakes when an obstacle is detected and passes it by overtaking it and carry on with one's journey not having to stop and never having to anyone stop because of you.[5]

We have also referred "Intelligent automatic overtaking system using vision for vehicle" detection paper. The Authors of this paper are Vicente Milanés, David F. Llorca. They have developed a vision system that was capable of detecting the preceding vehicle and its speed with sufficient accuracy, distinguishing between motorbikes, cars, and trucks. Once the width of the prior vehicle had been identified, and the autonomous manoeuvre activated, the system was capable of determining the length of the preceding vehicle to modify the host's speed to reduce the time it spends in the overtaking lane [6]

We had also referred "Overtaking Assistant System based on Fuzzy Logic". The Authors of this paper are Noor Cholis, Kuspriyanto. They have developed a decision- making system based on fuzzy logic using the Mamdani method. Due regard to overtaking on unidirectional and bidirectional roads, the OAS based on fuzzy logic is developed. In certain situations, the overtaking manoeuvre cannot be performed. Hence, this study takes note of pending as well as delayed overtaking. In the overtaking process, the decision-making process is carried out in the approaching stage or during the tailgating stage. Improper decision making will possibly result in a collision when lane changing, passing, or lane returning. [7]

## III. PROPOSED WORK

In our system we are using IR sensors that will help to detect the obstacles present in the front, right and left of the vehicle at some distance and capture all the details and send it to the system which will detect the obstacles and accordingly it will automatically overtake the vehicle, and after exceeding the vehicle again the control will be passed to the driver. This idea is more convenient

because using sensors will capture the data of obstacles very fast as compared to the vision system and will give perfect output.

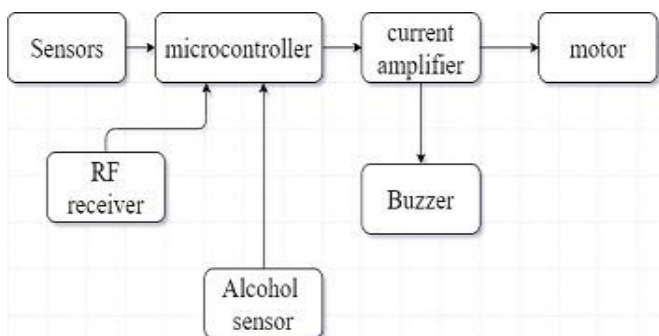

**Fig. 3. General Block Diagram of the System**

We are including one more feature in our Automatic overtaking system that will help to identify whether the driver is a drunkard or not? If the driver has consumed alcohol, then the buzzer will indicate it by making the sound, and the system will get to know that the driver is in the drunken state and the ignition of the vehicle will not start. This new feature will help the system to decrease the number of accidents on the road and provide safety for the drivers. We are adding this new feature in this system to make it better and useful for the people to avoid them from accidents. This feature is already implemented but not with an overtaking system. These features into a single system will be beneficial for society. This feature is essential in this system as not only it will detect the alcohol, but it will not allow the driver to drive the car and which will result in the reduction of accidents on roads and save people's life.

The automatic overtaking system will benefit so much to the people of society as its IR sensors will first detect the surrounding objects and send the digital signals to the microcontroller and then the microcontroller will detect the signs and based on that it will analyze that there is enough space to overtake the car, if found then it will automatically pass the vehicle, and there will be no chance of accident and no harm to the driver.

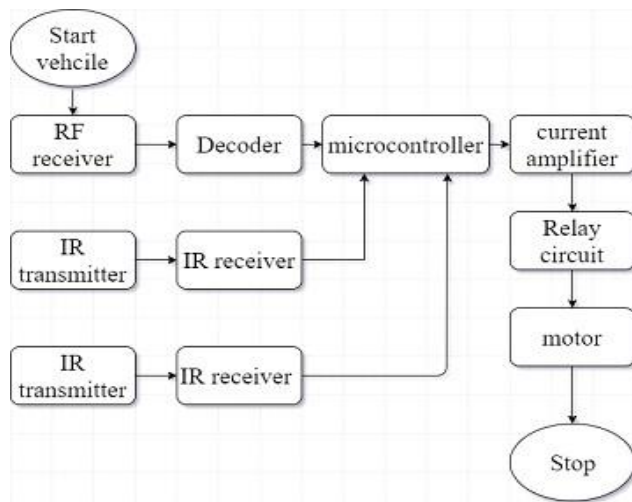

**Fig. 4. General Block Diagram of working vehicle**

Using this system the number of accidents daily will reduce to a minimal amount and will benefit so much to the people of society and because of the new feature added to alcohol detection will also help to cut it in more number and finally make it zero. The working of the Remote of the system is shown below.

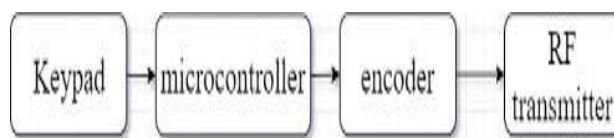

**Fig 5: Working of Remote**

The proposed system does not include this feature, and as we are adding this feature will make our policy more useful and advanced as compared to the existing one. The working of the Alcohol Detection System is shown below.

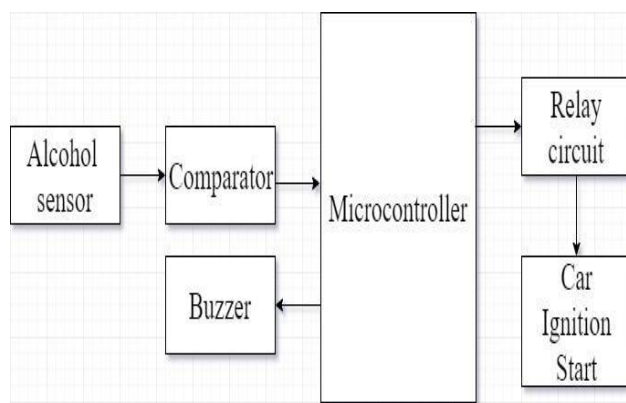
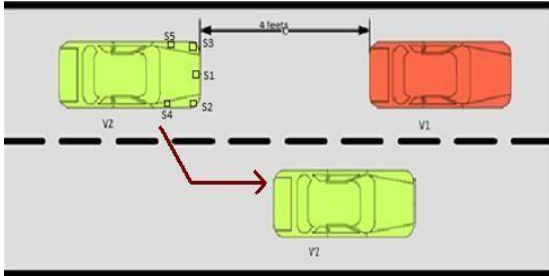

**Fig 6: Working of Alcohol Detection System**

#### IV. CASES OF OVERTAKING

There are three cases of overtaking. They are as below -

1. When there is a vehicle in the front, this vehicle will pass it from the right side.



**Fig 7: Case 1 of overtaking.**

2. When there is a vehicle in the front and on the left, the obstacle which is present to the left will not matter much as our vehicle will be overtaking from the right. (According to Indian Highway Rules) [1]

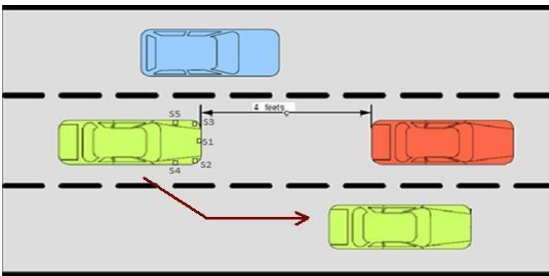

**Fig 8: Case 2 of overtaking.**

3. When there is a vehicle in the front and the right, firstly, our vehicle will first detect an obstacle in the front. Then it will check for the impediment to the right and overtake when the barrier on the right is not in the obstacle detection zone. If the obstacle on the right is very near to our vehicle, it will not decide to overtake; it will only reduce its speed.

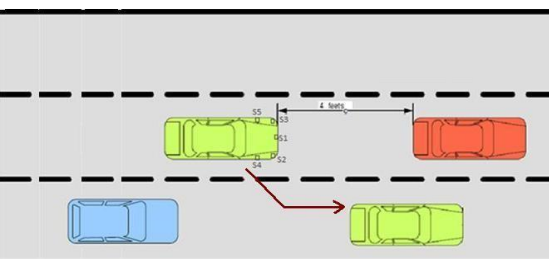

**Fig 9: Case 3 of overtaking.**

#### V. BENEFITS OF PROPOSED SYSTEM

1. A decrease in the number of accidents.
2. High chances of identifying Drink and Drive cases.
3. No Need for complete Manual awareness while overtaking by looking into the mirrors.
4. Very useful in Sports Cars where the driver may face severe injuries while overtaking.

#### VI. CONCLUSION

The Automatic Overtaking System has many advantages over the Existing System. This system will reduce the number of accidents per year which will be very beneficial to our Society. By applying Auto Restrictions on alcohol consumed drivers, there are High Chances to overcome the number of serious accidents that are caused due to the Drink and Drive Cases. This System will work on automation of Overtaking, so there is no need for Manual awareness. Also, this technology can be implemented on Sports Car so that we can achieve control over severe accidents and injuries that any sportsman has to face.

#### REFERENCES

1. Overtaking (162-169): Directgov- Travel and Transport.
2. 'PAT' – Pedestrian Avoidance Technology, implemented by Volvo.
3. Vamsi Mohan Peri, 'Fuzzy Logic Controller for an autonomous mobile robot', 2005.
4. <https://www.prsindia.org/policy/vital-stats/overview-road-accidents-india>.
5. Automatic Overtaking for Accident Avoidance and Automatic widescreen wiper; International Journal of Innovative Research in Computer and Communication Engineering Vol. 1, Issue 1, March 2013.
6. An intelligent automatic overtaking system using vision for a vehicle.

7. Overtaking Assistant System based on Fuzzy Logic; Article • January 2015 DOI: 10.12928/TELKOMNIKA.v13i1.499
8. PlamenPetrov and FawziNashashibi, “Planning and Nonlinear Adaptive Control for an Automated Overtaking Maneuver”, in International IEEE Conference on Intelligent Transportation Systems, 662-667, DOI: 10.1109/ITSC.2011.6083025, 2011.