

# Optical Fiber Methods for Measurement of Crack Width in TPB Concrete

B.Sobha,

Department of Physics, National Institute of Technology, Warangal-506004  
rangas2007@gmail.com

## Article Info

Volume 82

Page Number: 11683 - 11689

Publication Issue:

January-February 2020

## Article History

Article Received: 18 May 2019

Revised: 14 July 2019

Accepted: 22 December 2019

Publication: 21 February 2020

## Abstract

Concrete being a multi phase material is used widely in construction industry. It has high compressive strength and cost is less. But it is prone to cracking due to limited tensile strength. Parameters like characteristic length, fracture energy  $G_f$  critical crack width  $w_c$  are used to understand cracks in concrete. One can estimate the crack width either by measurement of crack mouth opening displacement (CMOD/COD) or as crack tip opening displacement (CTOD). Though several non optical and optical methods exist, they fail to provide information on crack opening and crack width. The latter is an important index from durability point of view. To this end the advantages of adopting optical fiber methods over other and our findings in TPB tests on pre-notched plain concrete samples using optical fiber sensors and CMOD estimation will be presented. Their relative sensitivity and current trends will be discussed.

Keywords: Crack mouth opening displacement(CMOD), Concrete, fiber optical sensors

## I. INTRODUCTION

Concrete is an important material used in construction industry. It is a multiphase composite material and has a quasi brittle nature. It is made up of a mixture of cement, coarse and fine aggregates, water, air and chemical admixtures. The process of crack detection and measurement of crack width is important to the rapidly developing field of SHM (structural health monitoring) [1-2]. Some of the important factors that lead to crack occurrence in concrete can be due to exposure to harsh environmental conditions, loading details when the structure is in service, hazards that may occur naturally [3]. Cracks are also known to occur in concrete due to ageing of the structure, thermal contraction upon drying, etc. If crack width is beyond 0.2–0.4 mm it leads to corrosion of reinforcement and durability problems. If the crack width is beyond 2mm it implies damage. The fracture process zone (FPZ) that lies ahead of the main crack mainly influences the behavior of concrete. Well known

mechanisms such as microcracking, deflection of the crack, bridging process of aggregates and the branching of crack, are known to principally determine the fracture behaviour of concrete.[5]. The fracture properties of concrete are influenced by the crack mouth opening displacement (CMOD). On the other hand the crack tip opening displacement (CTOD) is often difficult to determine as it is influenced by the details of what makes up the micro cracked zone. It is well known that the interrelationship between CMOD and CTOD is complex one. The presence of large extent of micro cracked zone in front of the crack tip decides the above mentioned complexity. The nondestructive techniques used for sensing cracks and crack monitoring are broadly divided into (1) non optical methods and (2) optical methods. The non optical methods include ultrasonic [6-7], impact echo, acoustic emission [8-9], IR thermography, coda wave interferometry [10], microwaves, radiography, electro mechanical

impedance [11] ground penetrating radar, while the optical methods include plastic optical fiber(POF) based techniques which(intensiometric, polarimetric, interferometric , spectroscopic ), fiber bragg gratings (FBGs), Digital image correlation (DIC)[12]and fiber loop ring down[13].

The particular choice of a method needs to address :  
(i) Need only detection of crack and trace its propagation.(ii) is it needed to measure the crack width at the chosen location or in distributed points. In recent times fiber optic sensors have been adopted for crack monitoring and detection. These include mainly plastic optical fiber (POF) and fiber bragg gratings (FBG). It is a practise to either test prenotched concrete prisms in three point bending or four point bending. The Fig 2 gives a listing of various fiber optic sensors for strain sensing [14]. The crack detection methods generally are (a) discrete sensing such as in three point bending(TPB)/four point bending (FPB) using prenotched specimens (b)quasi distributed sensing using several point sensors (c) fully distributed sensing methods (e) combination of the above methods (f) use of multiple sensors covering optical and non optical sensors

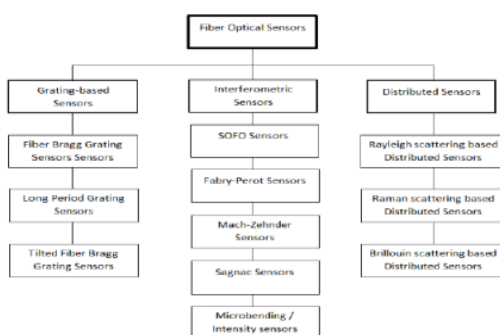

Fig 2 : Optical fiber sensors for strain sensing

## II. Discrete sensing

The various sensor geometries adopted for strain sensing using discrete point sensors include (a)hetero core fibber structure (b)tapered configuration (c)adopting index modulation (d) cladding removal (e)microbending and macrobend

structures[ 20 ]In the methods outlined below we have always adopted the cladding removal method( L is the guage length for cladding removal region) for strainsensing.We have adopted two methods on TPB specimen of M\_20 plain concrete viz. (a)measurement of phase difference using plastic optic fibers (POF)and (ii)measurement utilising a fiber bragg grating(FBG). The details of preparation of the concrete samples for three point bend (TPB) test have been described elsewhere [15-16].The casted specimens were placed in a water tank for curing and removed after 28 days. The overall set up is shown in Fig 3 and typical results are presented at selected frequencies in Fig 4. The sensing POF2 elongates under stress due to the crack developed at the prenotch. This affects the time taken for the light to travel through the strained optical fiber (POF2) in comparison to the time taken for travel through the fiber POF1 which is of equal length to POF2 but does not experience any strain. This explains the origin of the phase difference ( $\Delta\phi$ ) between the two transmitted light beams

. The light modulation frequency ( $f_M$ ) was varied from 50Hz to 10 KHz. If the elongation of the strained fiberis $\Delta L$ , it can be expressed using Eq (1).

$$\Delta L = \frac{\Delta\phi}{2\pi n_c} \lambda \quad \text{Eq. (1)}$$

Where  $n_c$  is the refractive index of the optical fiber core and  $\lambda$  is the optical wave length. The strain experienced by the POF2 is given by Eq (2) as

$$\epsilon = \frac{\Delta L}{L} \quad \text{Eq.(2)}$$

Where L= lengthover which cladding has been removed for POF2 and fixed across the prenotch of the concrete beam. The CMOD is calculated from product of strain  $\epsilon$  and width of the notch .

Table 1: CMOD using phase method at various  $f_M$  values

Frequency (Hz)	CMOD (mm) using LVDT	CMOD (mm) using POF Sensor	Difference
250	0.6	0.3	0.3
500	0.6	0.4	0.2
750	0.6	0.5	0.1
1000	0.6	0.7	0.1
10000	2.3	2.0	0.3

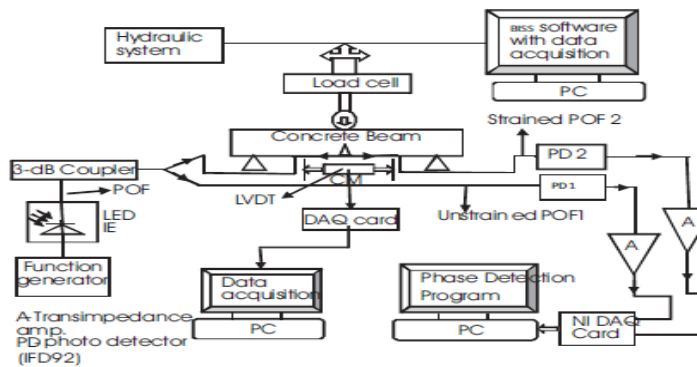

Fig 3 CMOD determination using phase difference method using POF

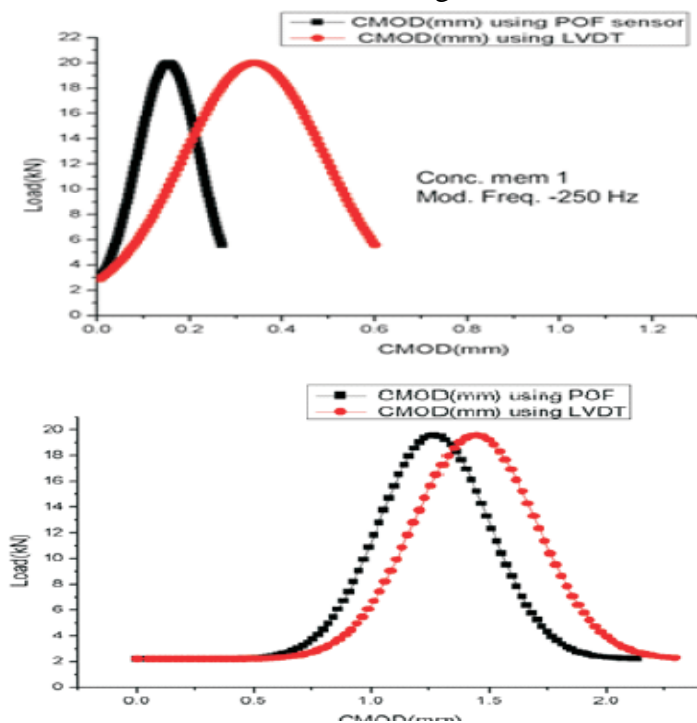

Fig 4: Typical results at two extreme  $f_M$  values. The following observations were made from the experimental plots: It is observed that there is a phase change of less than 90 degrees for all values of  $f_M$  used except for the  $f_M$  of 10 kHz. (b) The phase change

increases, with increase of  $f_M$  (c) as  $f_M$  is increased the transition of phase also becomes steeper. (d) The CMOD values obtained from the present method are shown in Table wherein we show the CMOD obtained using a LVDT. CMOD estimation using FBG: The Fiber Bragg grating (FBGs) finds wide application in quasi-distributed sensor. The FBG is inscribed in the core of an optical fiber. They have a number of advantages that include immunity to EMI, highly precise in sensing, durable and have a small size. Further, they are also, capable of being multiplexed along a single fiber when several sensors are used on large structures. FBGs also show superior corrosive resistance. Therefore they play an important role for sensing and measurements in harsh environments. These can include electrical noise, machine vibrations and also EMI. From the basic principle of FBG [17] the expressions for Bragg wavelength and change in Bragg wavelength are given by the equations below

$$\lambda_B = 2n_{eff}\Lambda \quad (3)$$

$$\text{And } \Delta\lambda_B = \lambda_B(1-P_e)\epsilon_z \quad (4)$$

In the above equations,  $n_{eff}$  is the effective refractive index,  $\Lambda$  is the grating period,  $P_e$  is the effective strain-optic constant and  $\epsilon_z$  is the applied strain. When a load is applied on the concrete specimen there is a linear shift of Bragg wavelength with strain. This occurs because there is a proportional change in grating period. This wavelength shift is related to the strain due to the stress that has been applied as mentioned previously (refer Eq. 4 above). The CMOD (in mm) can then be found the product of strain and notch width of the concrete beam.

The schematic of the experimental arrangement is presented in Fig 5. In Fig 6(a) we can observe linearity Bragg wavelength shift with CMOD. Also it can be inferred from Eq (3) that the Bragg wavelength is directly proportional to the effective

grating period  $\Lambda$ . Hence it is observed that there is an increasing strain experienced by the FBG from the start of load application. This increases the value of the effective grating period  $\Lambda$  and hence the increase in Bragg wavelength shifts. The strain so obtained has been used to calculate the CMOD from Eq. (4). The CMOD obtained using the FBG sensor in comparison with LVDT is shown in Fig. 6b. The table 2 presents the CMOD estimated by the above methods in our experiments

Table 2 : Estimated CMOD by POF and FBG sensors

S.No	Technique	CMOD value range
1	POF Fiber Intensity based technique	Around 0.3 mm (300 micromts)
2	Phase Technique	Up to 0.3 mm to 2 mm depending on frequency of modulation
3	FBG Technique	0.002 to 0.004 mm (2 micrometers)

### III. Quasi Distributed sensing

Multiplexed FBGs have been mostly adopted for this purpose in large structures. The FBGs exhibit high sensitivity, resolution, and wide dynamic range. Additionally they are immune to RFI, EMI. They can be interfaced to data communication systems. The most popular approach is based on wavelength division multiplexing (WDM). The schematic WDM scheme for FBGs is illustrated in Fig (7), [18-19].

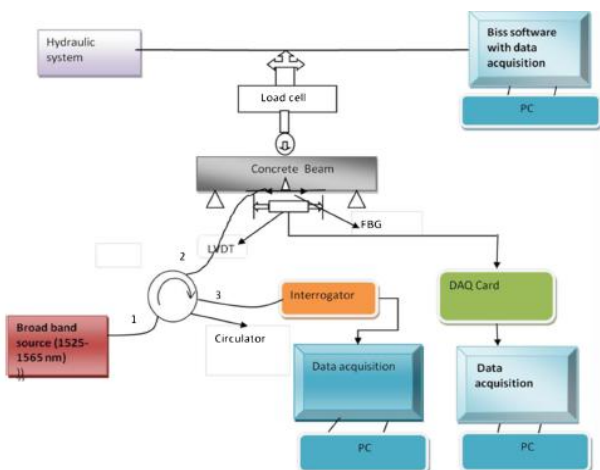

Fig5: Experimental arrangement for FBG method of CMOD estimation

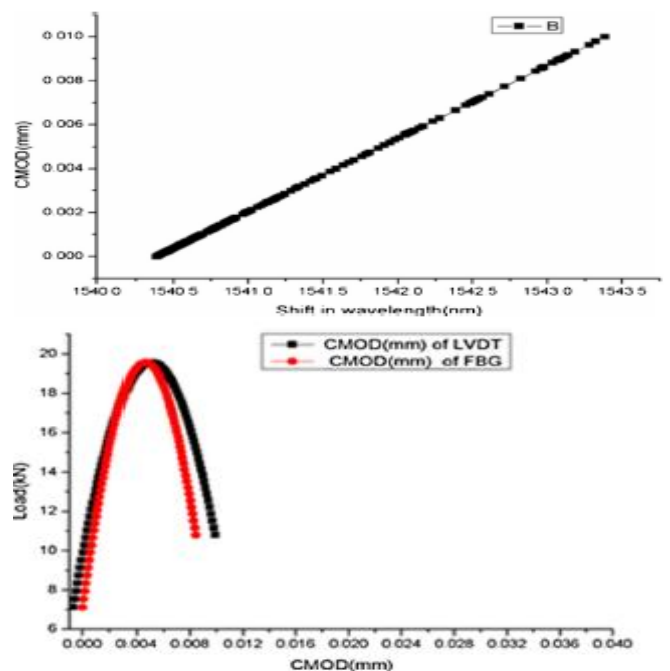

Fig 6(a) Linear plot of Bragg wavelength shift with CMOD (b) Comparison with LVDT data.

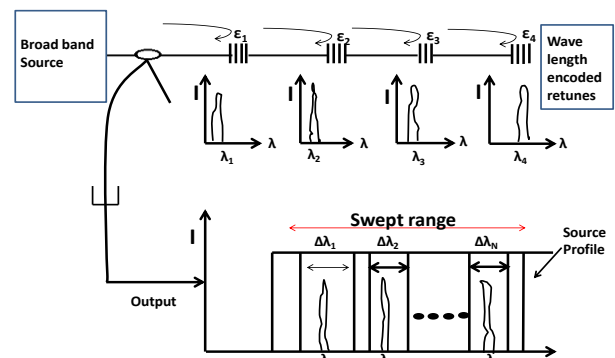

Fig 7: WDM scheme for FBGs

The FBG sensors are connected serially. All such connected sensors are needed to present sufficient separation of Bragg wavelengths. This is needed if one is to avoid spectral overlap. The interrogator uses this data to keep track of the individual sensors. Thus it is clear that number of sensors that can be multiplexed will be determined by the spectral band width of the broad band source plus the centre wavelength of each FBG. The various

interrogation techniques are covered in [ 20 ]. At present it is possible to have large ranges using the WDM technique wherein it is possible to accommodate more around 100 sensors per fiber.

#### IV. Fully Distributed sensing

There are currently several methods adopted in this category. These include several techniques such as Raman Optical Time Domain Reflectometry (OTDR), Brillouin OTDR, Brillouin Optical Time Domain Analysis (BOTDA)[21], Rayleigh OFDR/Optical Backscatter Reflectometer (OBR) BOFDA (Brillouin optical frequency-domain analysis) [22], and BOCDA (Brillouin optical correlation-domain analysis [23] and FBGs. The authors at[24] have employed polyimide coated distributed optical fiber sensor both in embedment and also on the surface of a TPB specimen of reinforced concrete. The crack formation was monitored using a commercial version of Rayleigh backscattering OFDR. The above covered techniques permit continuous monitoring. However they have low accuracy. It is not the aim of this paper to cover the above techniques any further.

#### V. Combination of methods using either Optical/non optical ones

(a) Recently [25] have applied a method combining both BOFDA and FBG sensors for crack monitoring in reinforced concrete the authors used several groups of BOFDA monitoring which makes it possible to predict the general location of the cracks situated internally from the data collected for strain. This is followed by searching for the exact location for surface cracks using FBG. The width of the crack can be estimated from the FBG sensors at such cracks

(b) The draw backs of the above systems for real time application are usually their high cost or sensor probes. In recent times smart aggregates chief contents are a protected PZT patch have

paved way for embedment into concrete This approach has been adopted at [26] for damage detection and crack detection in structural members of concrete

(c) Another notable methodology for crack monitoring combines a number of smart materials. Crack monitoring using a number of smart materials using a combination of smart and fiber optic sensors has been reported at[27] and illustrated in Fig (8). Here the cracks in the concrete beam are monitored on global scale using a Fiber optic polarimetric sensor (FOPS) The piezoelectric wafer active sensor (PWAS) was utilised to study the electromechanical admittance (EMA) signatures. The changes in the frequencies of the peak amplitude of these signatures are related to the changes in the natural frequencies of the structure caused either due to loading or cracking .The FBG is used for local crack monitoring in the at the centre of the concrete beam

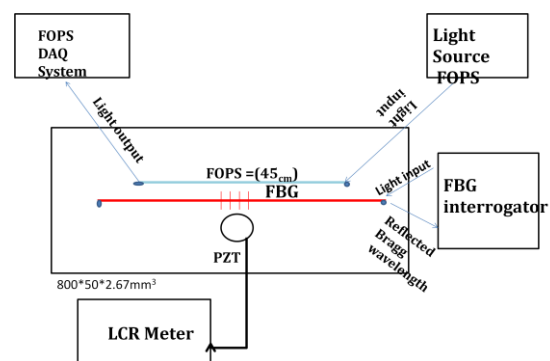

Fig(8): The concrete beam with multiple smart sensors [27]

#### VI. REFERENCES

- [1] H M Elwalwal, S.B.Hi, Mahzan and Ahmed N. Abdalla "Crack Inspection Using Guided Waves (GWs)/Structural Health Monitoring (SHM): Review,"J. of Applied Sciences, vol 17,no.8,pp 415-428, 2017
- [2] S.K. Verma, S.S.Bhadauria, andS.Akhtar,"Review of Non-destructive Testing Methods for Condition Monitoring of Concrete Structures,"Jou. Construction

- Engineering , Vol. 2013, Article ID 834572, 11 pages, 2013.
- [3] G Karaiskos, A Deraemaeker , D G Aggelis and D Van Hemelrijck , " Monitoring of concrete structures using the ultrasonic pulse velocity method ," Smart Mater. Struct.,vol.24, no.11, 113001 (18pp),2015
- [4] M.B. Otieno, M.G.Alexander, and H.D. Beushausen,"Corrosion in cracked and uncrackedconcrete :influence of crack width, concrete quality and crack reopeningMag. Concr. Res.,vol62, no(6),pp393-404,2010
- [5] A. Rama Chandra Murthy, G.S. Palani, and N.R. Iyer, "State-of-the-art review on fracture analysis of concrete structural components", Sadhana, Vol. 34, pp. 345-367, 2009
- [6] G.Concuand N.Trulli, "Concrete Defects Sizing by Means of Ultrasonic Velocity Maps", Buildings, vol 176, no.8, pp1-19, 2018
- [7] N.Ahmada, R.A. Rahima, H.A.Rahima, M H FRahiman,"A Review of Ultrasonic Application on Non-destructive Testing Method for Concrete Structure,"JurnalTeknologi (Sciences & Engineering) , vol. 70, no.3, pp119-122, 2014
- [8] J. Saliba, A. Loukili, J.P. Regoin , D. Grégoire, L. Verdon, G. Pijaudier-Cabot , "Experimental analysis of crack evolution in concrete by the acoustic emission technique ,"Frattura ed Integrità Strutturale,vol.34,pp300-308, 2015
- [9] J.M.Congpeng , A.W.C. Oreta and S.Hirose ,"Monitoring Damage Using Acoustic Emission Source Location and Computational Geometry in Reinforced Concrete Beams,"Appl. Sci. ,vol.8,no.2, p189, 2018
- [10] T. Planès, E. Larose , "A review of ultrasonic Coda Wave Interferometry in concrete," Cement and Concrete Research ,vol.53,no.8 pp 248-255, 2013
- [11] Y.Y Lim and C.K.Soh," Electro-Mechanical Impedance (EMI)- Based Incipient Crack Monitoring and Critical Crack Identification of Beam Structures ", Research in Nondestructive Evaluation,vol.25 25 ,no.2, pp82-98,2014
- [12] S. Bhowmikand S Ray," An experimental approach for characterization of fracture process zone in concrete ", Engineering Fracture Mechanics 211 , pp401–419, February (2019)
- [13] P.Sahay, M.Kaya and C. Wang,"Fiber Loop Ringdown Sensor for Potential Real-Time Monitoring of Cracks in Concrete Structures: An Exploratory Study " , Sensors , vol.13, no.1,pp 39-57,2013
- [14] Ä.Barrias , J,R Casas and S. Villalba, " A Review of Distributed Optical Fiber Sensors for Civil Engineering Applications ", Sensors ( Basel), vol.16, no.5, 35 pages, 2016
- [15] K.Samrajyam, B.Sobha and T.D.G.Rao," POF based local(point) sensor for crack opening studies:Application in concrete ",i-manager's Journal on Civil Engineering, Vol.1,No.4,pp 35-40 September - November 2011
- [16] K.Samrajyam ,B..Sobha,T.D.G.Rao,andR.L.N.SaiPrasad,"Pl astic Optic Fibre(POF) based phase difference measurement method for estimation of crack mouth opening displacement(CMOD) in concrete ",i-manager's Journal on Civil Engineering, Vol.4, No.2,pp.13-18,1 September - November 2011
- [17] K.Samrajyam , R.L.N.Sai Prasad , T.D.G .Raoand B.Sobha," Fiber Bragg Grating (FBG) sensor for estimation of Crack Mouth Opening Displacement (CMOD) in concrete", J Opt . vol 44, no.4,pp : 346–352., 2015
- [18] W. Chung and D. Kang, "Full-scale test of a concrete box girder using FBG sensing system",Engineering Structures vol .30, pp 643-652, 2008
- [19] W.Chung and D.Kang , "Structural behavior of concrete box bridge using embedded FBGsensors", Sensors and Smart Structures Technologies for Civil, Mechanical, and Aerospace Systems 2012, eds.M.Tomizuka,C.Yun and J.P.Lynch , Proc. of SPIE Vol. 8345, 83451X
- [20] C.E. Campanella, A. Cuccovillo ,C.Campanella , A.Yurt and V.M. N. Passaro, "Fibre Bragg Grating Based Strain Sensors: Review of Technology and Applications ", Sensors , vol. 18, 2018, 18, 27 pages , 3115, 2018

- [22] H. Zhang, "Study on PPP-BOTDA technology for concrete crack monitoring," *Applied Mechanics and Materials*, vol. 333-335, pp. 1582–1585, 2013
- [23] C. K. Leung, K. T. Wan, D. Inaudi et al., "Review: optical fiber sensors for civil engineering applications," *Materials and Structures*, vol. 48, no. 4, pp. 871–906, 2013
- [24] M. Imai, R. Nakano, T. Kono et al., "Crack detection application for fiber reinforced concrete using BOCDA-based optical fiber strain sensor," *Journal of Structural Engineering*, vol. 136, no. 8, pp. 1001–1008, 2010.
- [25] A. Barrias, J.R. Casas, and S. Villalba, "Embedded Distributed Optical Fiber Sensors in Reinforced Concrete Structures—A Case Study" *Sensors* vol 18, no.980, published March 2018
- [26] Q.Zhang and Z.Xiong, "Crack Detection of Reinforced Concrete Structures Based on BOFDA and FBG Sensors", *Shock and Vibration*, Volume 2018, published Sept 2018, Article ID 6563537, 10 pages
- [27] T.Jiang, Y Hong, J. Zheng, L. Wang and H. Gu, "Crack detection of FRP reinforced concrete beams using embedded piezo ceramic smart aggregates", *Sensors*, vol.19, no.1979, 20 pages, 2019,
- [28] M. Maheshwari, V. G. M. Annamdas, John H. L. Pang, .Asundi and S.C.Tjin, "Crack monitoring using multiple smart materials; fiber-optic sensors and piezosensors", *International Journal of Smart and Nano Materials*, vol 8, no.1, pp 41-55, 2017